

45LA

TANDEM AXLE UTILITY TRAILER

G.V.W.R. 4,500#	AXLES Two 3500# Axles w/ 1 Elec. Brake
G.A.W.R. (EA. AXLE) 2,960#	SUSPENSION Multi-Leaf Spring
COUPLER 2" A-Frame	TIRE ST205/75-15 Load Range B
SAFETY CHAINS ¼" Grd. 30 w/ Safety Latch Hook (2 ea.)	WHEEL 15 X 5 White Spoke 5 Bolt
JACK 2000# Top Wind (Bolted On)	FLOOR 2" Pine
TONGUE 4" Channel	LIGHTS D.O.T. Stop, Tail, Turn and Clearance
TOP RAIL 2" X 3" X 3/16" Angle	ELEC. PLUG 6 Way
FRAME 2" X 3" X 3/16" Angle	FINISH (PREP) Acid Etched w/White Phosphorus, Undercoated w/Panther 813 & Two Coats Primer
CROSSMEMBERS 2" X 3" X 3/16" Angle	FINISH Painted w/ 2 Coats High Solid <i>Supreme</i> Acrylic Automotive Grade Enamel, and Pinstriped
UPRIGHTS 14" Tall 2" X 2" X 1/8" Angle	
FENDERS 9" X 72" Rolled Formed w/ Back	

STANDARD FEATURES

- 3500# Axles w/ 1 Electric Brake
- Complete Break-A-Way System
- Safety Chains Attached w/ Cold Rolled Eyelets
- Lower Jack Support Plate
- w/ Charger
- Floor Secured w/ 5/16" Torx Screws

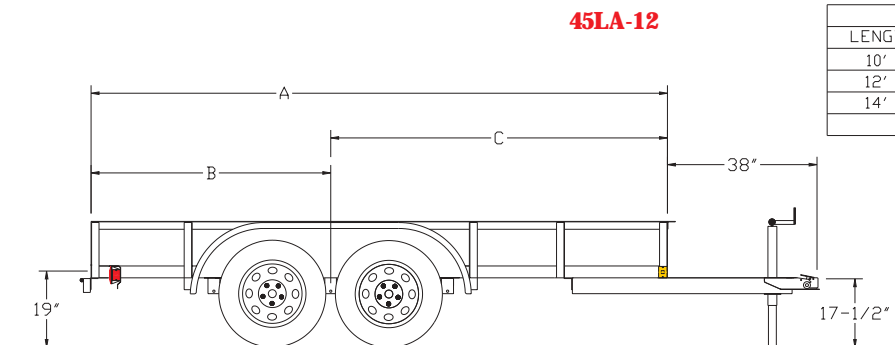

LENGTH	DIMENSIONS		
	A	B	C
10'	121-1/2"	48-1/2"	73"
12'	145-1/2"	60-1/2"	85"
14'	169-1/2"	66-1/2"	103"

OPTIONS

NBK1	No Electric Brakes (Farm or Off Road Use Only)
BRK2	Electric Brakes On Two Axles
HYD1	Hydraulic Brakes On One Axle w/ Atwood Actuator
HYD2	Hydraulic Brakes On Two Axles w/ Atwood Actuator
SRAMPS	4' Slide In Ramps
RG	Rampgate for 45LA
SPMT	Spare Mount (Side)
SP	15" Spare Tire & Wheel - Load Range B
BD2	2" Bulldog Coupler
AT2.5.16	2-5/16" Atwood Coupler
BD2.5.16	2-5/16" Bulldog Coupler
FUJ	2K Fold-Up Jack
HST	Higher Sides (Each Additional Foot)
ENEX	Enclosed w/ Expanded Metal (Per Sq. Ft.)
ENSH	Enclosed w/ Sheet Metal (Per Sq. Ft.)
SF	1/8" Diamond Plate Steel Floor (Per Sq. Ft.)
SAR	Shock Assist Option For Rampgate
STPK	Tie Down Pockets (Each)
HDF	Heavy Duty Frame (4" X 3" X ¼" Angle)

Effective January 1, 2003 (Specifications and Options subject to change without notice.)