

12FT

PRO SERIES TILT BED EQUIPMENT TRAILER

G.V.W.R.	12,000#	AXLES	Two 6000# Cambered Axles w/ Elec. Brakes
G.A.W.R. (EA. AXLE)	5,560#	SUSPENSION	Multi-Leaf Slipper Spring w/ Equalizer
COUPLER	2-5/16" Bulldog	TIRE	7.50 X 16" Load Range E
SAFETY CHAINS	1/4" Grd. 70 w/ Safety Latch Hook (2 ea.)	WHEEL	16 X 6 White Spoke 8 Bolt
JACK	2000# Top Wind, Bolted On	FLOOR	2" Pine
TONGUE	5" Channel Fold Back	LIGHTS	D.O.T. Stop, Tail, Turn and Clearance
TOP RAIL	(none)	ELEC. PLUG	6 Way
FRAME	6" Channel	FINISH (PREP)	Acid Etched w/White Phosphorus, Undercoated w/Panther 813 & Two Coats Primer
CROSSMEMBERS	3" Channel + 2-7/8" Pipe	FINISH	Painted w/ 2 Coats High Solid <i>Supreme</i> Acrylic Automotive Grade Enamel, and Pinstriped
UPRIGHTS	(none)		
FENDERS	10 3/4" X 72" Diamond Plate Teardrop w/ Back		

STANDARD FEATURES

- Lower Jack Support Plate
- Two 6,000# Axles w/ 2 Electric Brakes
- Complete Break-A-Way System w/ Charger
- Diamond Plate Knife Edge
- 102" Wide Overall 80" loading width between the fenders
- 2-5/16" Bulldog Forged Coupler
- Safety Chains Attached w/ Cold Rolled Eyelets
- Floor Secured w/ 5/16" Torx Screws
- Spare Tire Mount
- Hydraulic Dampening System
- Unique Two Piece Main Frame
- Fold Back Tongue w/ Raised Coupler

12FT-16

LENGTH	DIMENSIONS			
	A	B	C	D
16'	202-1/2"	101-1/2"	101"	13°
18'	225-1/2"	112-1/2"	113"	12°
20'	249-1/2"	121-1/2"	128"	11°

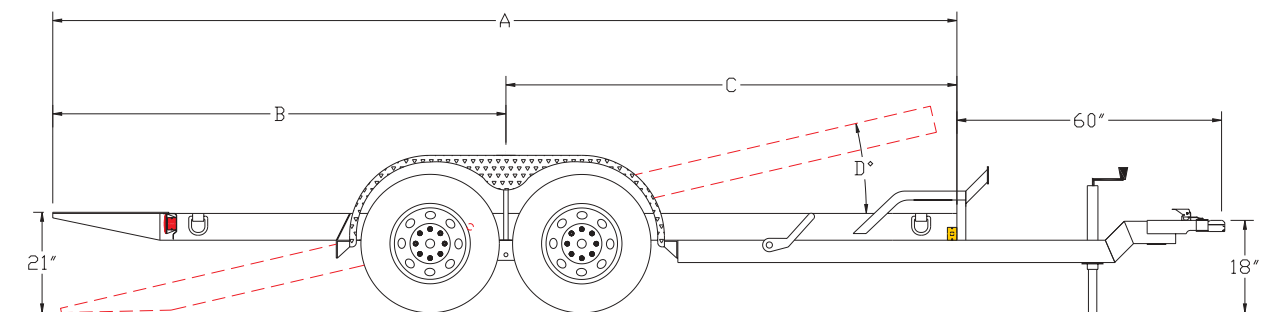

OPTIONS

NBK2	Electric Brake on 1 Axle Only
HYD1	Hydraulic Brakes On 1 Axle w/ Adjustable Demco Actuator
HYD2	Hydraulic Brakes On 2 Axles w/ Adjustable Demco Actuator
SP	16" Spare Tire & Wheel - Load Range E
DLJ	7K Drop Leg Jack
SF	1/8" Diamond Plate Steel Floor (Per Sq. Ft.)
HDLJ	10K Heavy Duty Drop Leg Jack (Top Wind)
AP	Adjustable Pintle In Channel

Effective January 1, 2003 (Specifications and Options subject to change without notice.)