

# 12EQ

## TANDEM AXLE EQUIPMENT TRAILER

<b>G.V.W.R.</b> 12,000#	<b>AXLES</b> Two 6,000# Cambered Axles w/ Elec. Brakes
<b>G.A.W.R. (EA. AXLE)</b> 6,000#	<b>SUSPENSION</b> Multi-Leaf Slipper Spring w/ Equalizer
<b>COUPLER</b> Adjustable 2-5/16" Bulldog	<b>TIRE</b> LT235/85 16" Load Range E
<b>SAFETY CHAINS</b> 1/4" Grd. 70 w/ Safety Latch Hook (2 ea.)	<b>WHEEL</b> 16 X 6 White Spoke 8 Bolt
<b>JACK</b> 7K Top Wind Jack (Bolted On)	<b>FLOOR</b> 2" Pine
<b>TONGUE</b> Integral With Frame	<b>LIGHTS</b> D.O.T. Stop, Tail, Turn and Clearance
<b>TOP RAIL</b> (none)	<b>ELEC. PLUG</b> 6 Way
<b>FRAME</b> 8" Channel	<b>FINISH (PREP)</b> Acid Etched w/White Phosphorus, Undercoated w/Panther 813 & Two Coats Primer
<b>CROSSMEMBERS</b> 3" Channel	<b>FINISH</b> Painted w/ 2 Coats High Solid <i>Supreme</i> Acrylic Automotive Grade Enamel, and Pinstriped
<b>FENDERS</b> 9" X 72" Double Square Broke, Diamond Plate Teardrop w/ Back	

### STANDARD FEATURES

- Two 6,000# Axles w/ 2 Electric Brakes
- Complete Break-A-Way System w/ Charger
- 7K Drop Leg Jack (Bolted On)
- Adjustable Coupler in Channel
- Expanded Metal in Bottom of Tongue
- Safety Chains Attached w/ Cold Rolled Eyelets
- Spare Mount Curb Side
- Floor Secured w/ 5/16" Torx Screws
- Two 5' Fold Up Ramps w/ Support Leg
- Four D-Rings, 2 per Side
- Reflective Marker Tape
- 32" Dove Tail

**12EQ-16**

DIMENSIONS			
LENGTH	A	B	C
14'	170"	67"	103"
16'	194"	79"	115"
18'	218"	91"	127"

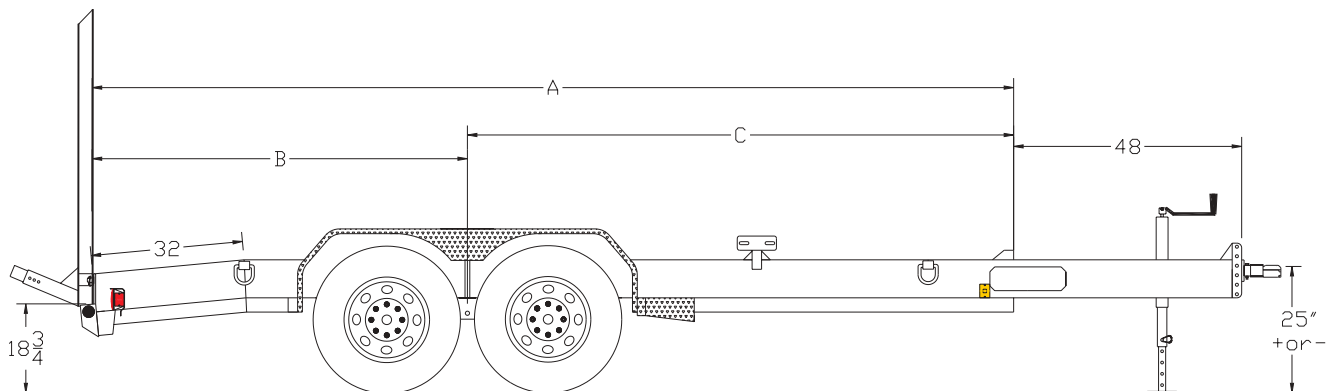

### OPTIONS

<b>HYD2</b>	Hydraulic Brakes On 2 Axles w/ Adjustable Demco Actuator
<b>SP</b>	16" Spare Tire & Wheel - Load Range E
<b>SF</b>	1/8" Diamond Plate Steel Floor (Per Sq. Ft.)
<b>HDLJ</b>	10K Heavy Duty Drop Leg Jack (Top Wind)
<b>AP</b>	Adjustable Pintle In Channel

Effective January 1, 2003 (Specifications and Options subject to change without notice.)