

10SR-10

TANDEM AXLE SINGLE RAM DUMP

G.V.W.R.	9,990#	AXLES	Two 5200# Cambered Axles w/ Elec. Brakes
G.A.W.R. (ea. Axle)	5,080#	SUSPENSION	Multi-Leaf Spring w/Equalizer
COUPLER	2-5/16" Atwood	TIRE	ST225/75-15 Load Range D
SAFETY CHAINS	¼" Grd. 70 w/ Safety Latch Hook (2 ea.)	WHEEL	15 X 6 White Spoke 6 Bolt
JACK	2000# Top Wind (Bolted On)	FLOOR	12 Ga. Smooth Steel
TONGUE	5" Channel	LIGHTS	D.O.T. Stop, Tail, Turn and Clearance
FRAME	6" Channel	ELEC. PLUG	6 Way
CROSSMEMBERS	6" Channel	FINISH (PREP)	Acid Etched w/White Phosphorus, Undercoated w/Panther 813 & Two Coats Primer
BED CROSSMEMBERS	3" Channel & 3" X 2" Tubing	FINISH	Painted w/ 2 Coats High Solid <i>Supreme</i> Acrylic Automotive Grade Enamel, and Pinstriped
BED SIDE RAILS	3" X 2" Tubing		
FENDERS	9" X 72" Teardrop		

STANDARD FEATURES

- 20" 12 GA. Sides
- Complete Break-A-Way System w/Charge Line
- Protective Lighting
- 1 piece 12GA. Floor
- Lockable Control Unit
- 1 piece 2 Way Style Rear Gate
- 3/4 Tie Rail on Sides & Front
- 9 Stake Pockets (Sides & Front)
- Self Contained, Electric/Hydraulic Single Cylinder Lift
- 45 Degree Dump Angle
- Enclosed Pump & Battery Box Mounted in Front of Bed

10SR-10

DIMENSIONS			
LENGTH	A	B	C
10'	120"	47-3/8"	72-5/8"

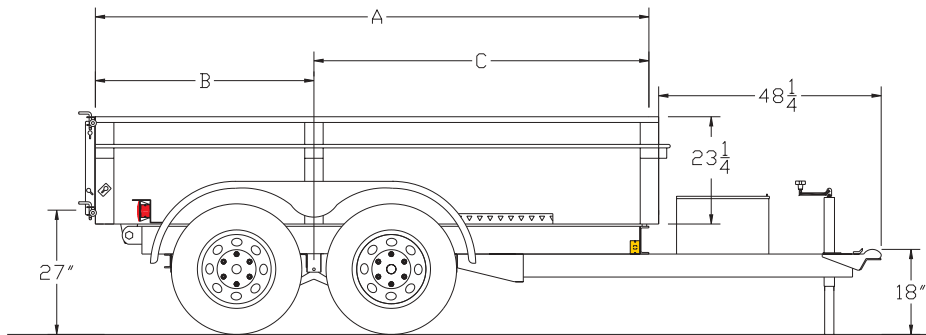

TRAILER WEIGHTS & CAPACITIES

LENGTH	EMPTY WEIGHT	BOX CAPACITY
10'	2490#	3.75 Yards

Effective January 1, 2003 (Specifications and Options subject to change without notice.)